

G-Type Meter (1P2W)

NJ G-type meter for low voltage

This 1P2W meter series can provide with the easy way to directly access solutions for the residential & commercial AMI applications

Key Benefits

- ▶ Time-of-Use Metering
- ▶ kWh, kvarh and kVAh Metering
- ▶ Measurement Profiling
- ▶ RS-485 Daisy-Chain Port
- ▶ DLMS Protocol
- ▶ Power Quality Monitoring



▶ Easy to Direct Access

With the adoption of IEC 62056 and DLMS, this meter provides the easy way to directly access to the metering data for AMR and AMI applications

▶ Time-of-Use Meter

Adopting an integrated solution, the meter provides an optimal TOU metering alternatives for medium load customers of residential & commercial applications:

- Up to 4-tariff metering
- Up to 4-self reads : energy, demand & PF
- Support TOU pending program

▶ Various & Versatile Measurement

With four-quadrant, vector-summed, & bi-directional metering and measurement capabilities, the meter can measure and record an accumulated & interval energy consumption of active, reactive and apparent power:

- Up to 8-metering recording channels
- User-defined kW(h), kvar(h), kVA(h)
- Max. demand Cum. demand with time stamp
- User-define PF calculation

▶ Load Profile Capacity

For the interval metering, the meter measures and records the user-defined interval data into the non-volatile memory:

- Up to 8-channel for interval data metering
- Up to 6,240-records for 4-channel/15-minutes
- Status event of interval data
: power fail, DR, program update, TOU update, abnormal wiring, & tariff of interval data

▶ Communications

With RS-485 communication port, the meter can be read and programmed locally and remotely up to 38,400-bps. For the detachable modem, the meter supplies an operating power for modem like PLC and RF:

- IEC 62056 DLMS protocol
- DC 12V, 2.5VA

▶ Instrumentation & PQ

With the meter software, the technicians can test and verify the installation and operation of the meter:

- Per-phase measurement : power, voltage, ampere, and phase angle

The meter provides with the PQ monitoring capabilities:

- Voltage-THD, Sag & Swell

▶ Self Diagnosis

To ensure the reliable meter operation, the meter detects and indicates the faulty conditions:

- Under voltage, reverse flow, memory & battery error

To avoid the tampering & theft operation, the meter detects and indicates the faulty conditions:

- Magnetic force, abnormal temperature, and cover-open

▶ External Output

The meter provides an external output which is an open-collector type and is programmable by user:

- Time Switch, remote load control, current limiting

For Residential & Commercial Customers in the Smart Grid Market, the NJ G-Type meter Series are waiting for your best choice...

◆ Dimensions :

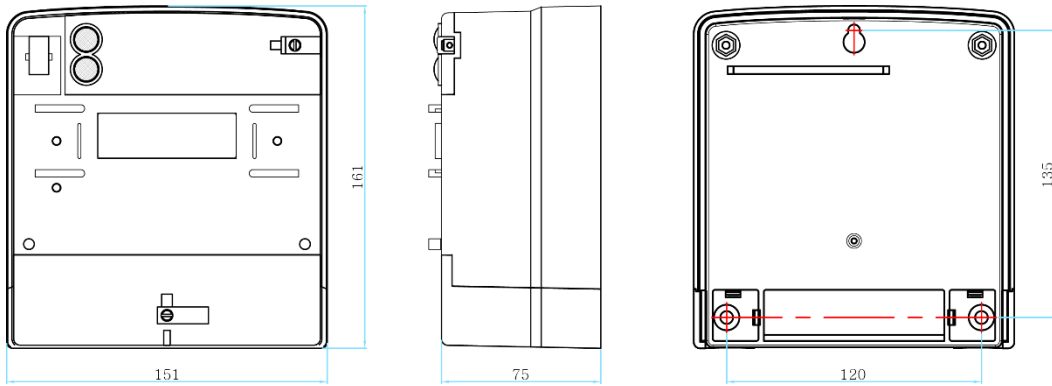

◆ Specifications and Technical Data :

➤ Voltage	220V (Dynamic operating range = 100~264V)
➤ Current	10(100)A, 2.5(5)A
➤ Frequency	50/60 Hz ($\pm 5\%$ tolerances)
➤ Temperature	-25°C to +55 °C (operating range)
➤ Humidity	0 to 100% (non-condensing)
➤ Power consumption	Less than 2W
➤ Accuracy	With full load and light load $\pm 1.0\%$ for kWh With full load and light load $\pm 2.0\%$ for kvarh With full load and light load $\pm 2.0\%$ for kVAh
➤ Starting current	Conforms to the IEC requirements (less than 0.004Ib & 0.002In)
➤ Creep	No more than 1 pulse per measured quantity
➤ Startup delay	Less than 3 seconds from power application to pulse accumulation
➤ Clock	Built-in real time clock with a backup battery(3.6V/1,200mAh)
➤ Communication	Remote communication up to 38,400 baud
➤ Standards	IEC 62052-11 <i>Electricity metering equipment (a.c.)-General requirements, tests and test conditions</i> -Part 11: Metering equipment IEC 62053-21 <i>Electricity metering equipment a.c.-Particular requirements</i> -Part 21: Static meters for active energy (classes 1 and 2) IEC 62053-23 <i>Electricity metering equipment a.c.-Particular requirements</i> -Part 23: Static meters for reactive energy (classes 2 and 3) IEC 62056-21 <i>Electricity metering-Data exchange for meter reading, tariff and load control</i> -Part 21: Direct local exchange IEC 62056-42 <i>Physical layer services and procedures for connection oriented asynchronous data exchange</i> IEC 62056-46 <i>Data Link Layer using HDLC-protocol</i> IEC 62056-53 <i>COSEM Application Layer</i> IEC 62056-61 <i>OBIS Object Identification System</i> IEC 62056-62 <i>Interface Objects</i>



12, Gimhae-daero 2635beon-gil, Gimhae-si, Gyeongsangnam-do, Republic of Korea

TEL +82-55-326-9001 FAX +82-55-326-9004

www.namjun.com